

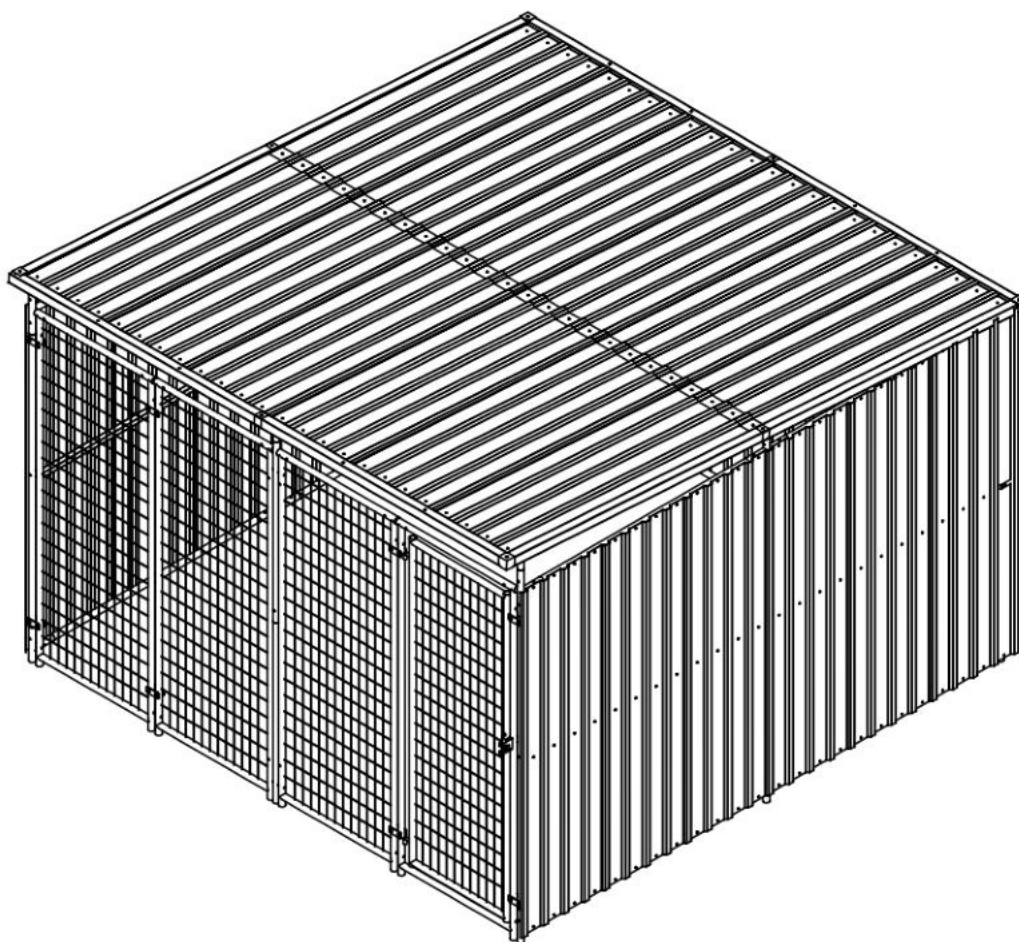













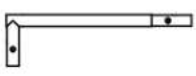





DOGNY TYP 7

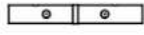



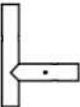
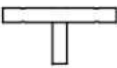
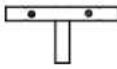
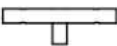
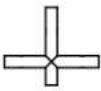
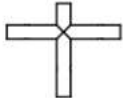







POZOR: NĚKTERÉ DÍLY MAJÍ OSTRÉ HRANY.
PŘI MANIPULACI S RŮZNÝMI KUSY JE NUTNÉ BÝT OPATRNÝ, ABYSTE SE VYHNULI NEŠTĚSTÍ. VZHLEDEM K BEZPEČNOSTI, PŘED ZAČÁTKEM STAVBY SI PROSÍM PŘEČTĚTE BEZPEČNOSTNÍ INFORMACE POSKYTNUTÉ V TOMTO NÁVODU. PŘI MANIPULACI S KOVOVÝMI DÍLY POUŽÍVEJTE RUKAVICE.

BP1		18	Q7		2
BP11		6	Q8		1
BP12		6	Q8A		1
Q1		4	Q9		1
Q2		2	Q10		2
Q3		4	Q11		1
Q4		2	Q12		1
Q5		1	Q13		2
Q6		2	QD1		3

QD2		1
QD3		1
T1		2
T2		2
T3		1
T4		1
TT1		2
TT2		2
ZU1		2

ZU2		1
ZU3		1
ZU4		1
ZU5		1
ZA1		4
ZA2		4

G1		2
G2		1
M7		4
L7		1
K37		16



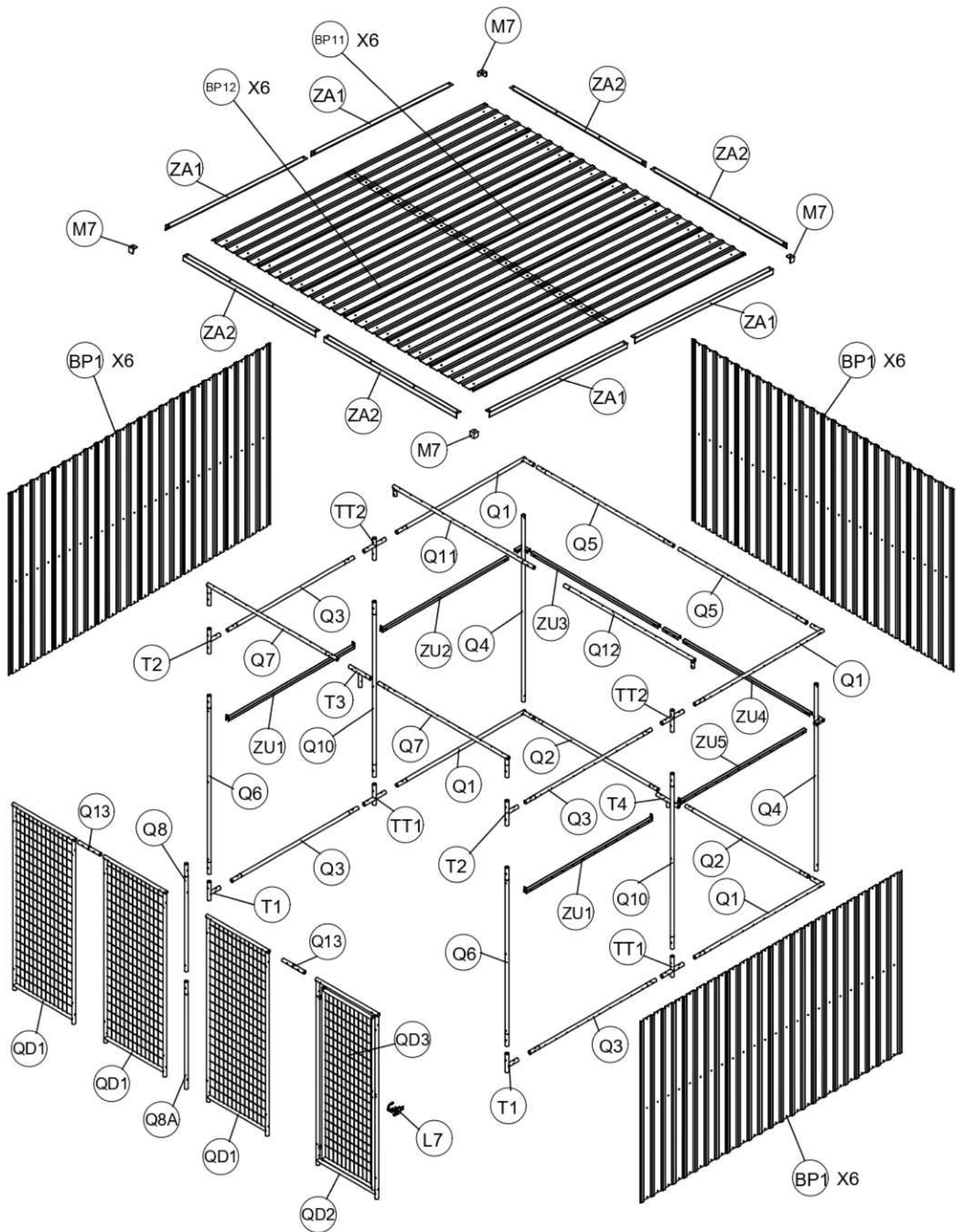

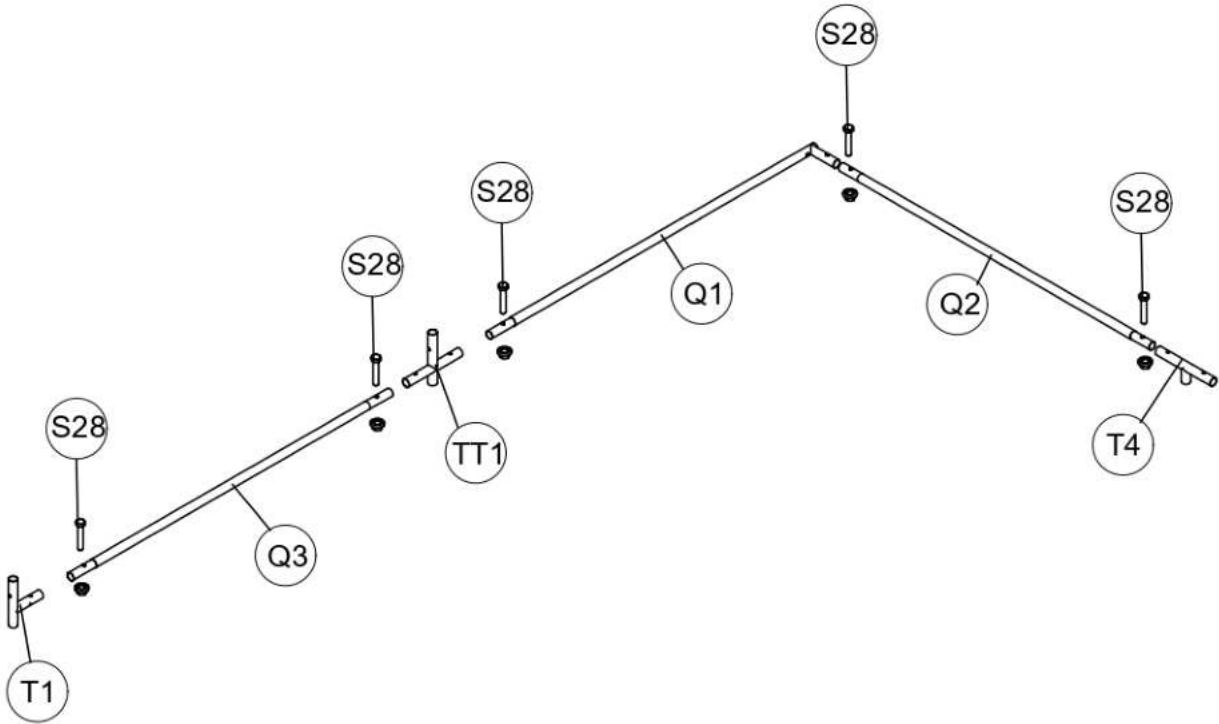
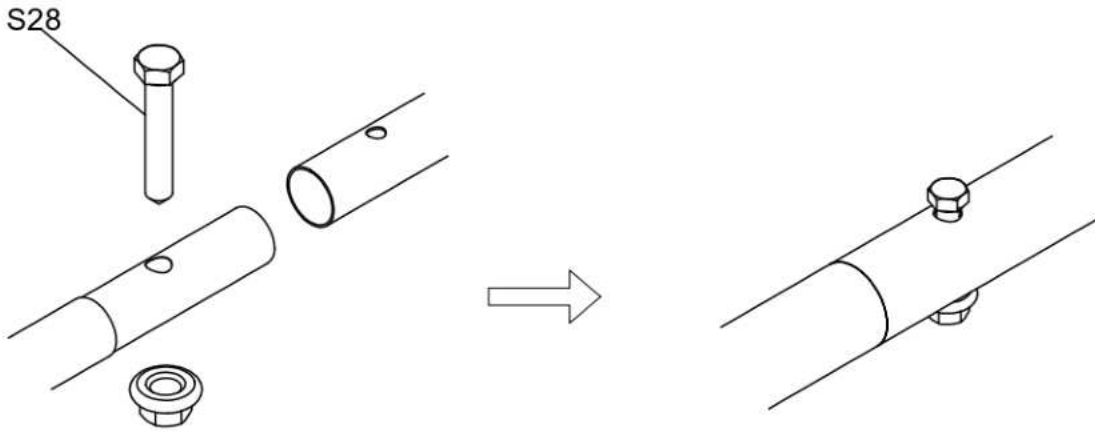
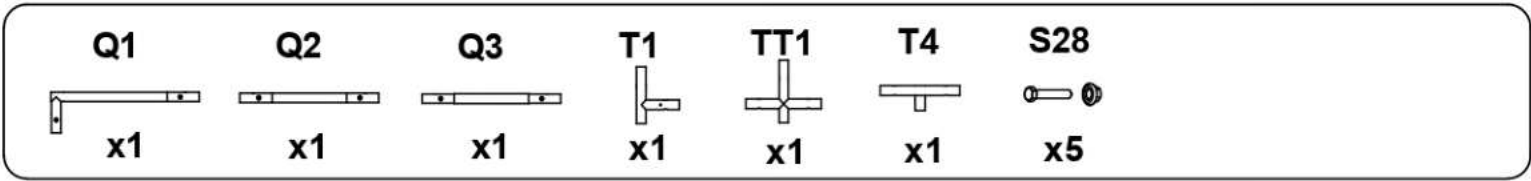

S26		304
S28		61
S29		4
S30		2
S31		4



1.





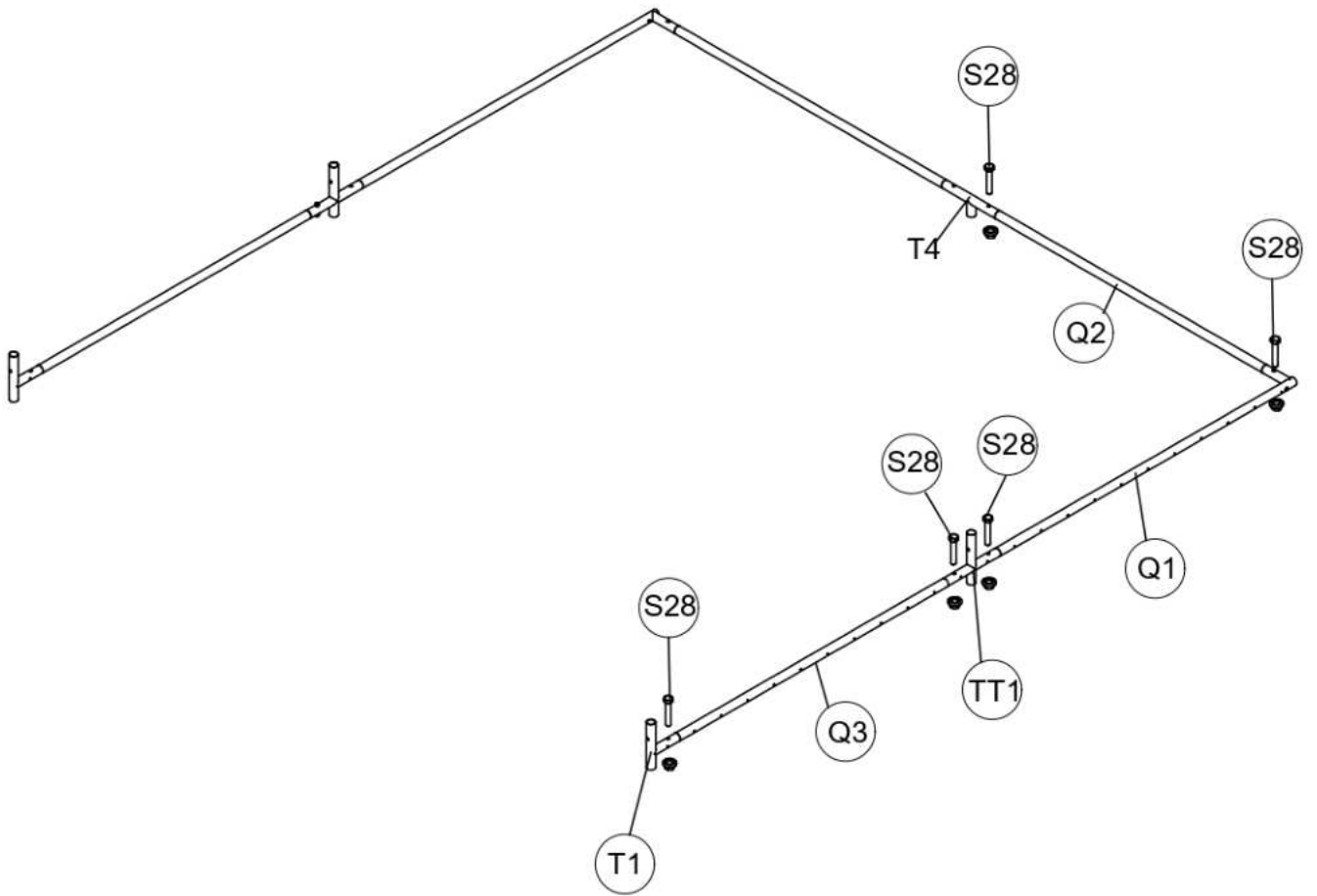
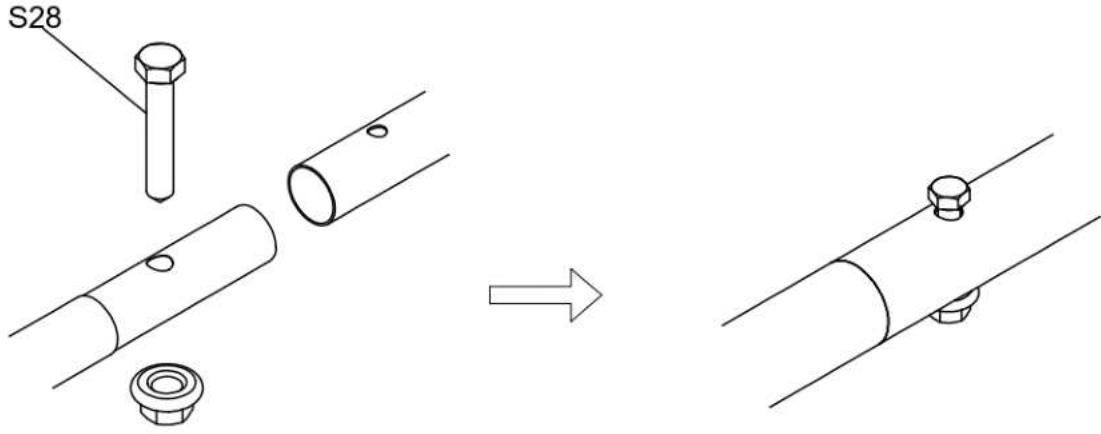

2.

Q1  x1	Q2  x1	Q3  x1	T1  x1	TT1  x1	S28  x5
---	--	--	--	---	--







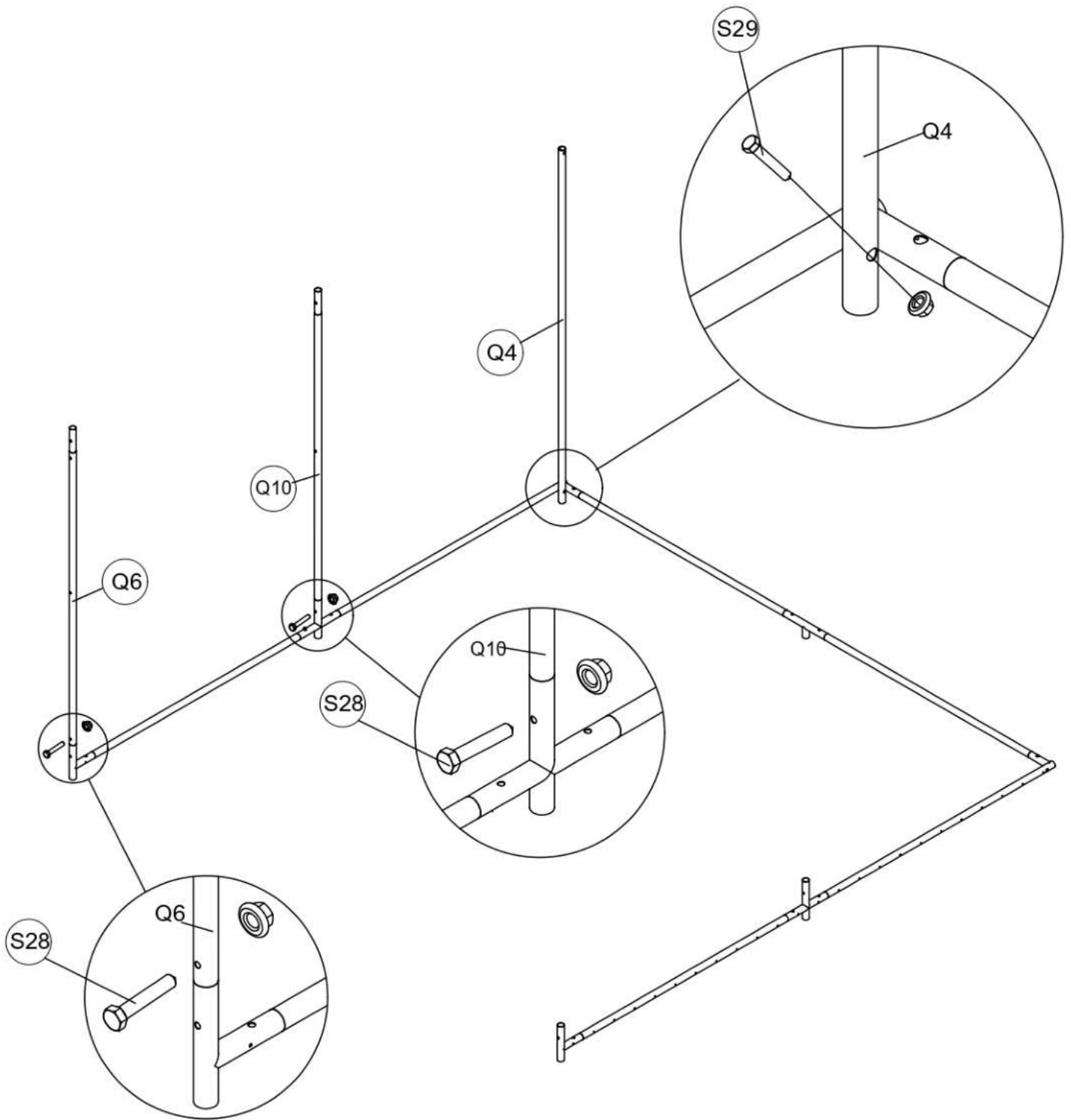



3.

Q4	Q6	Q10	S28	S29
				
x1	x1	x1	x3	x1







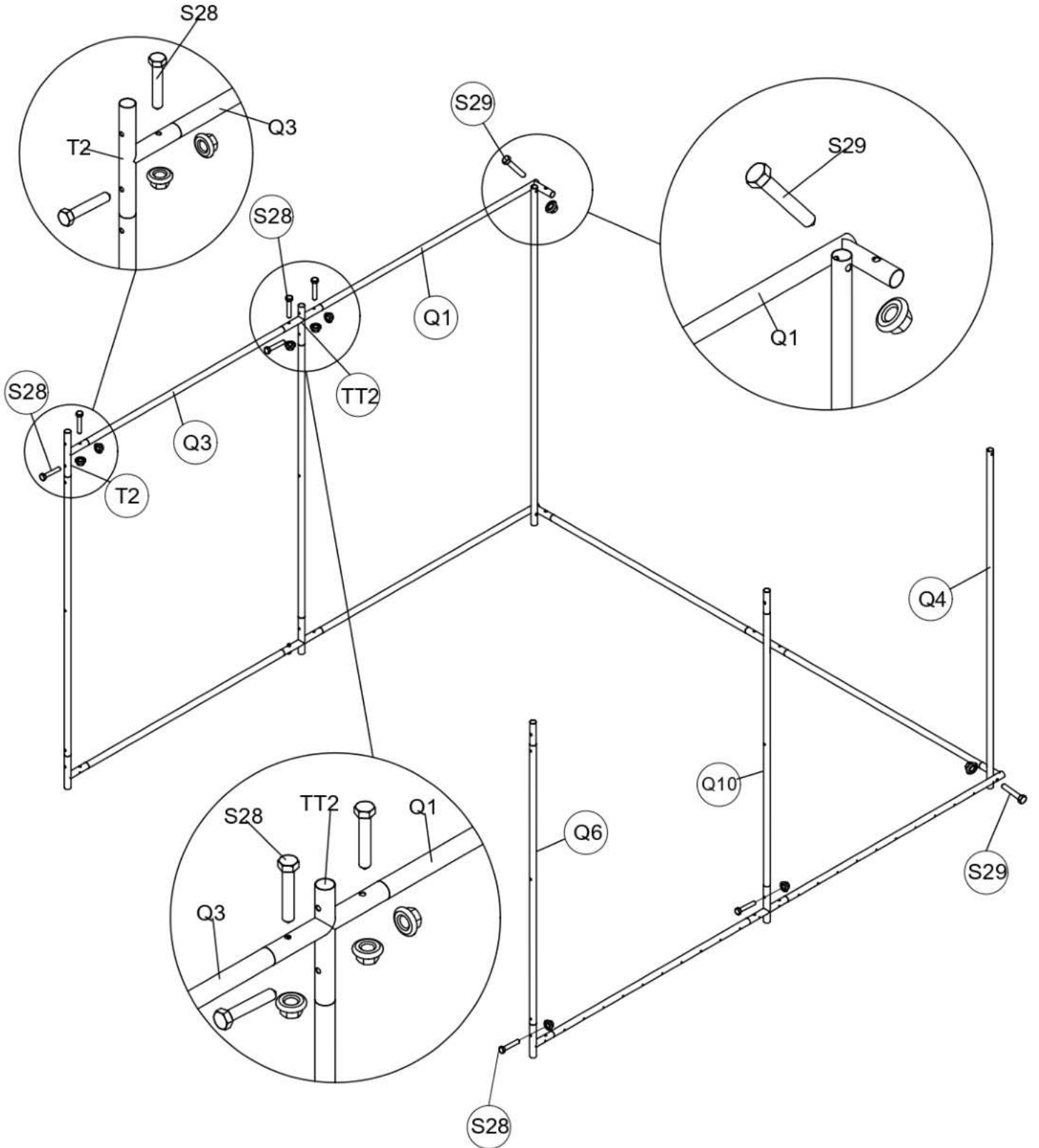

4.

Q1  x1	Q3  x1	Q4  x1	Q6  x1	Q10  x1	T2  x1	TT2  x1	S28  x7	S29  x2
---	--	--	--	---	---	---	---	---



5.

Q1  x1	Q3  x1	T2  x1	TT2  x1	S28  x5	S29  x1
---	--	--	---	---	---

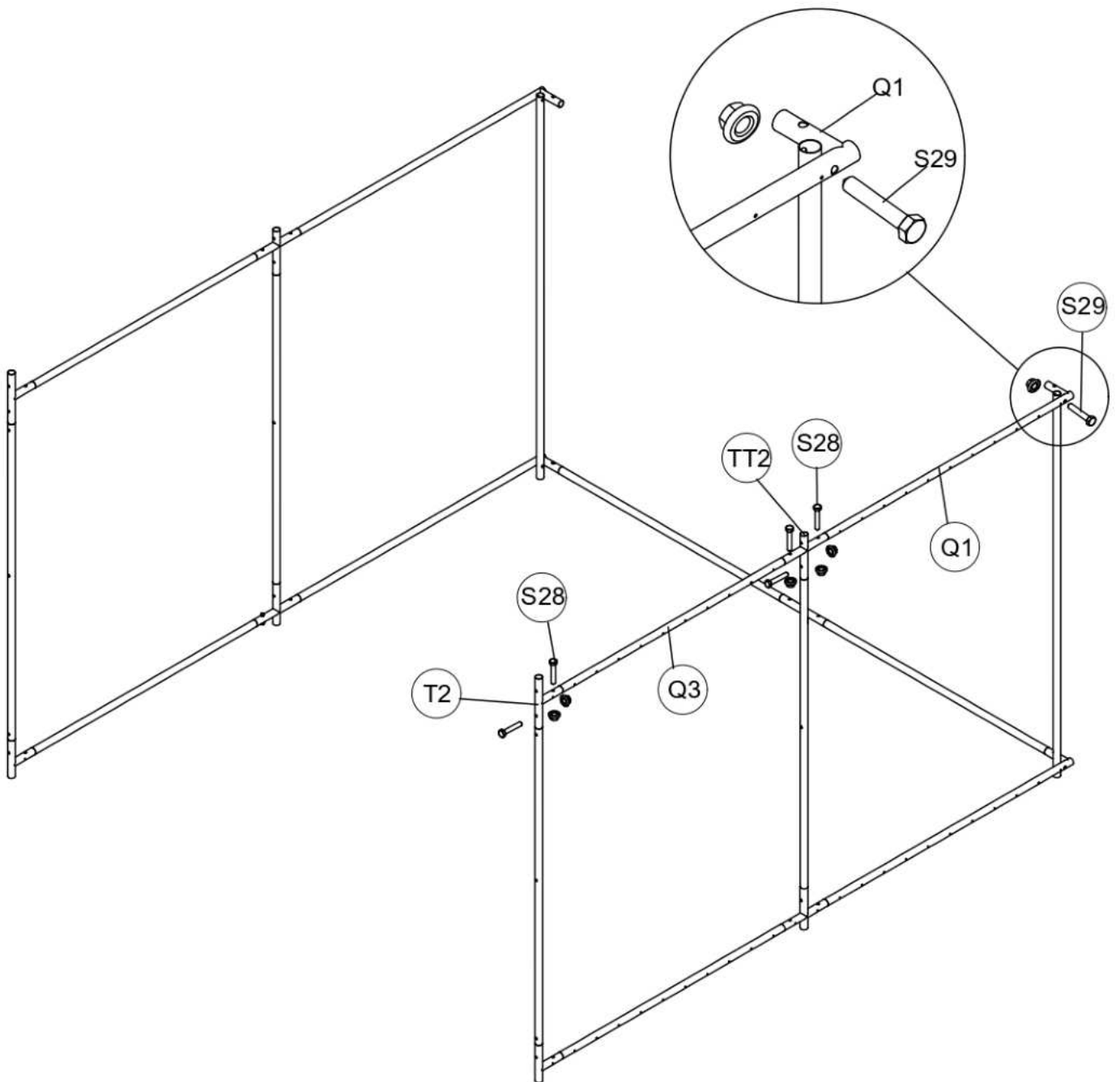

6.



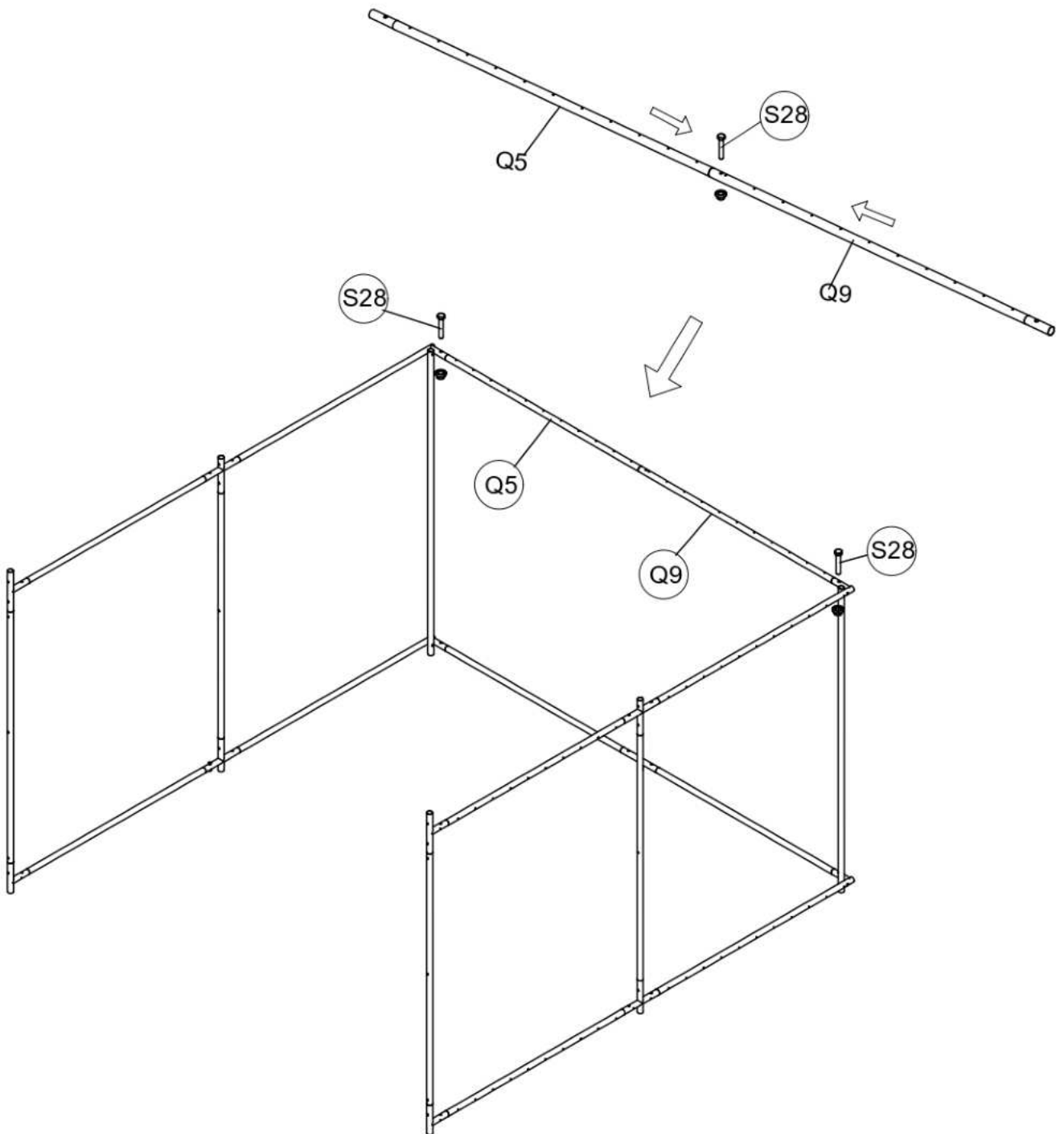

Q5  x1	Q9  x1	S28  x3
--	--	---

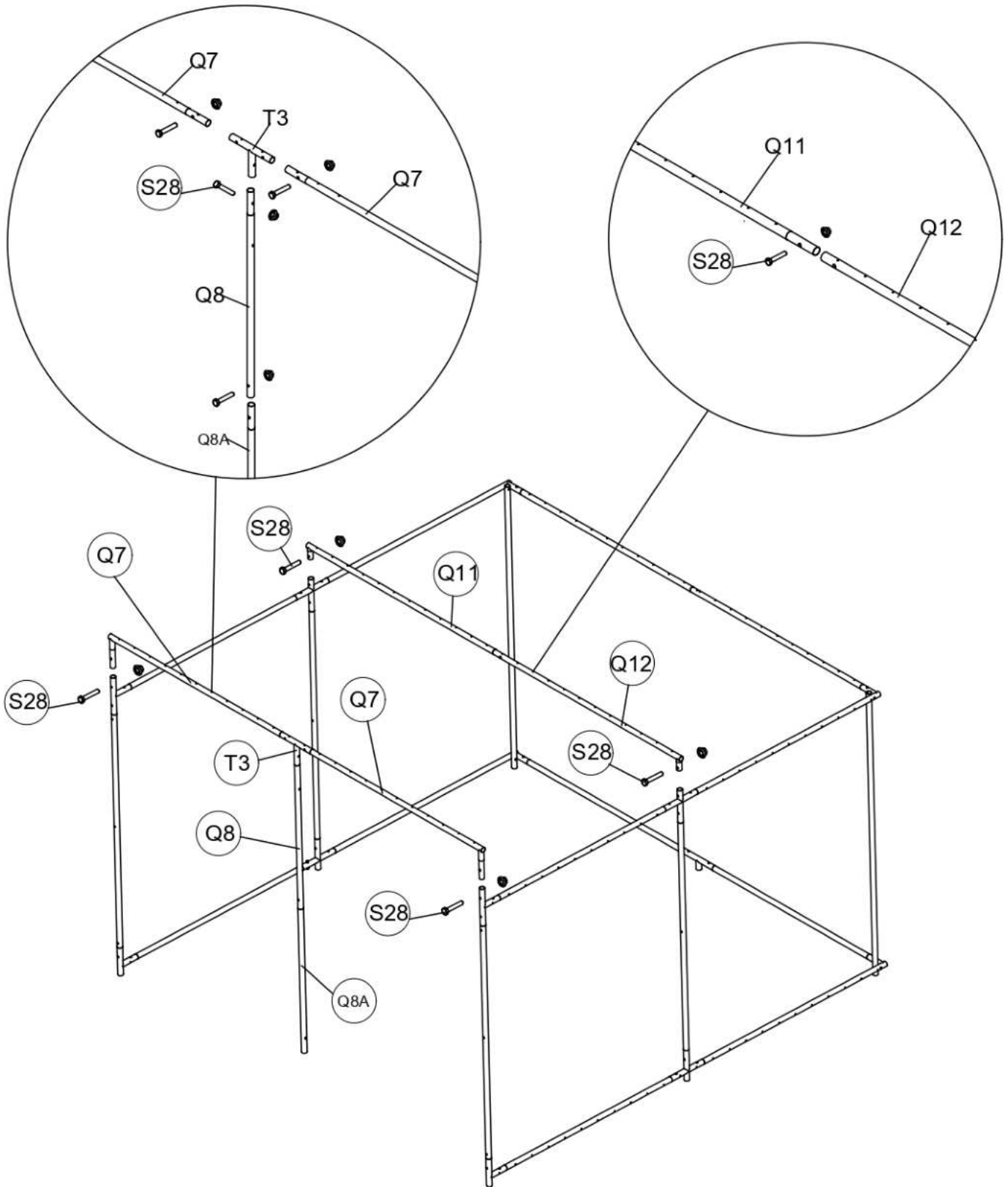
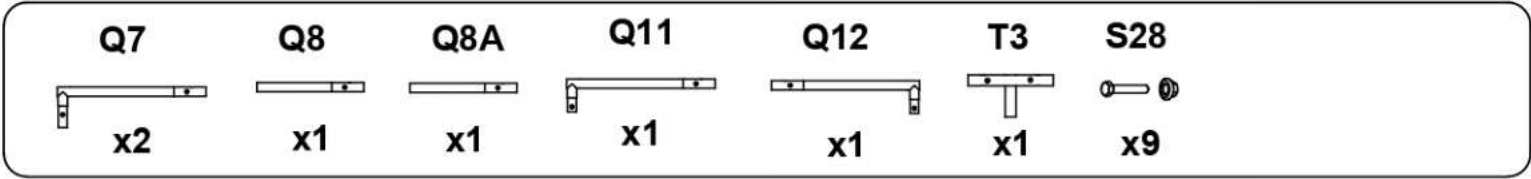

7.



8.

QD1  x3	QD2  x1	Q13  x2	K37  x8	S28  x12
--	---	---	---	--

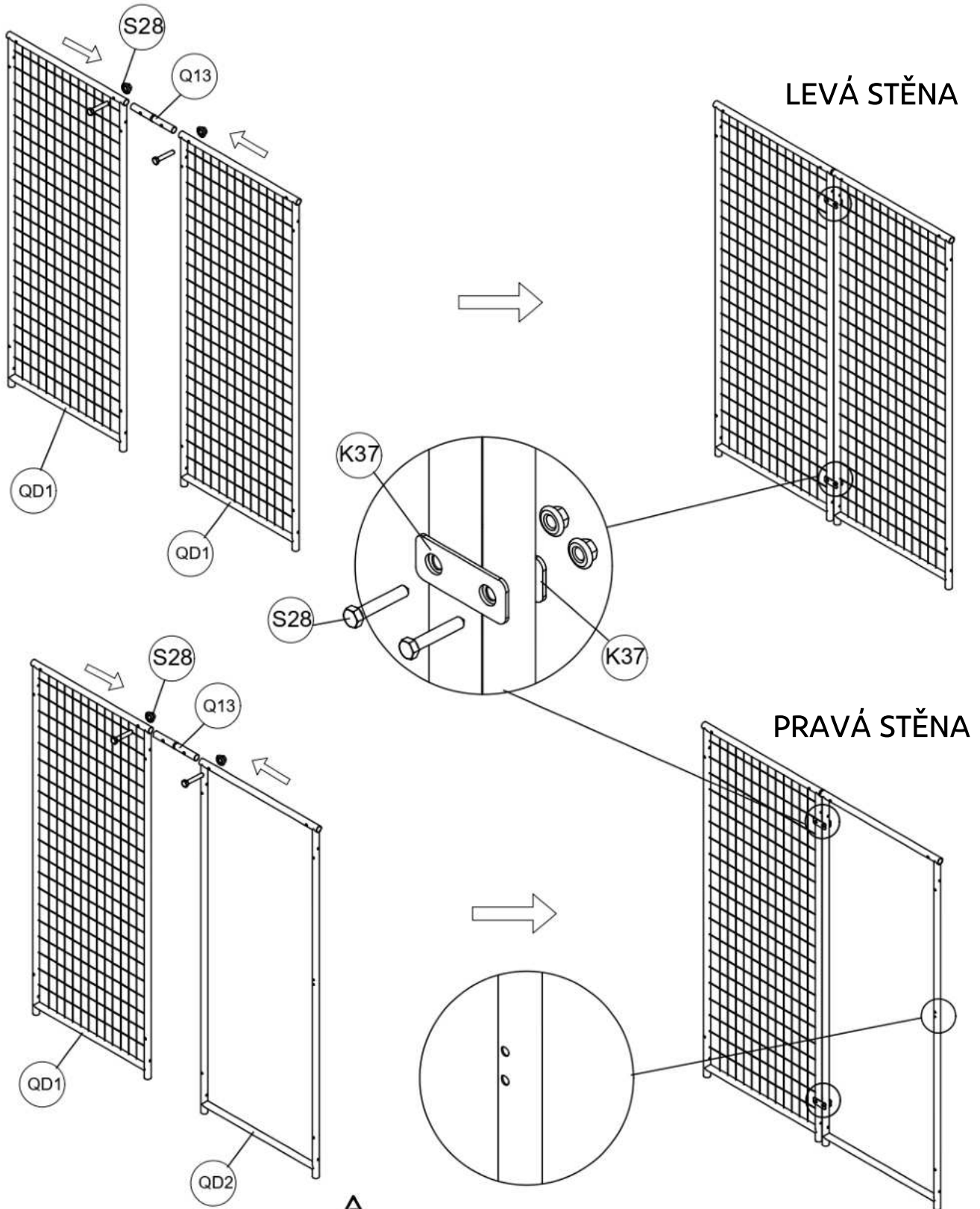

 Směrování pozornosti

9.

K37 **S28** **S30**



x8



x8



x2

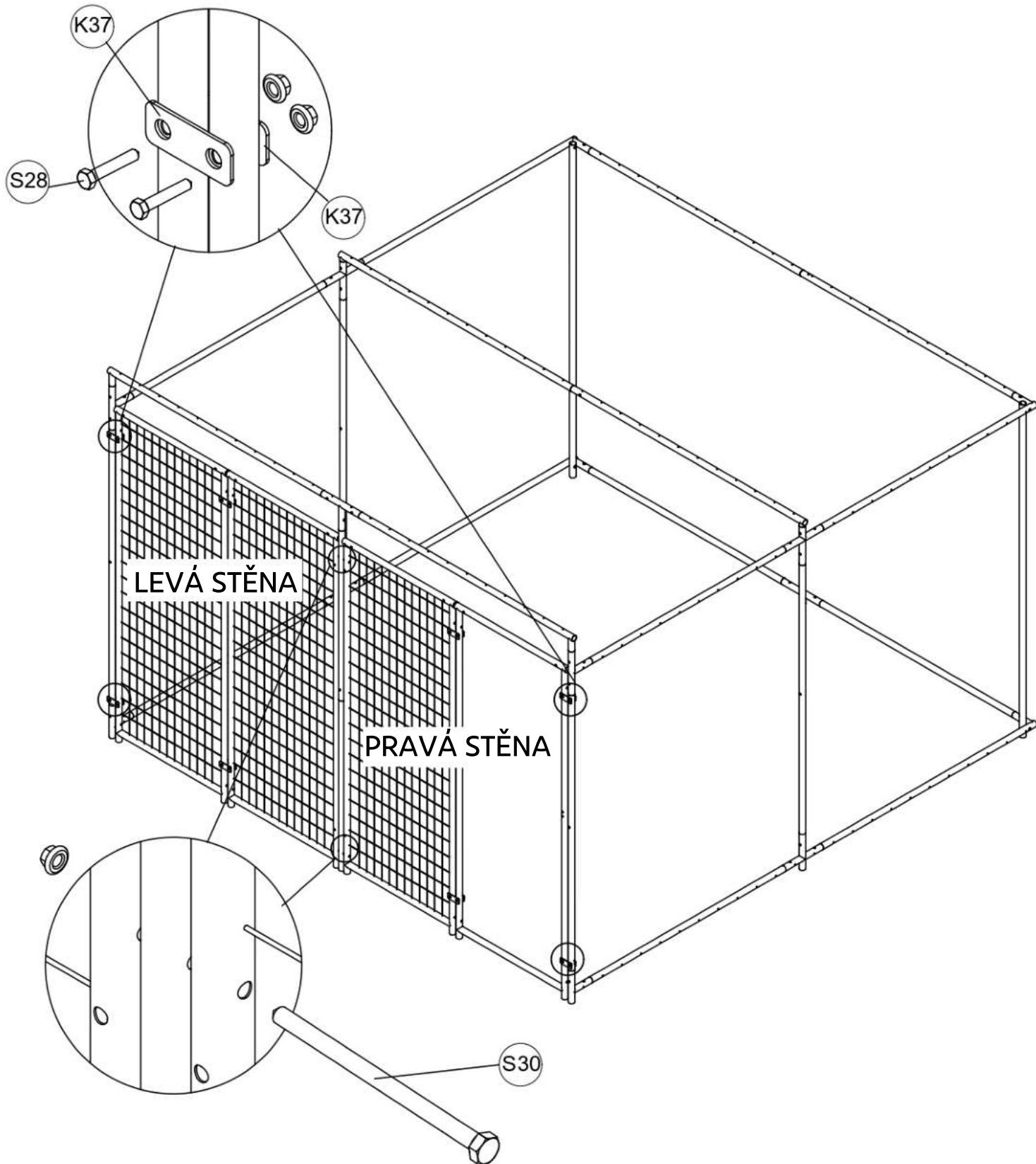

10.

QD3

x1

L7

x1

S31

x4

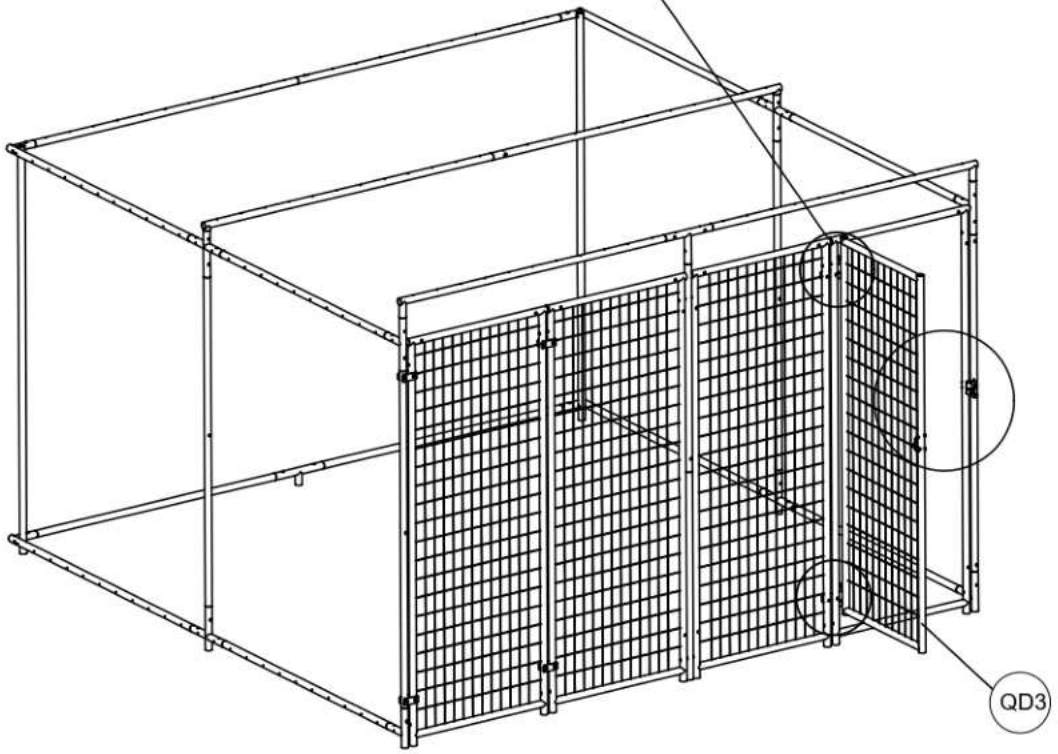
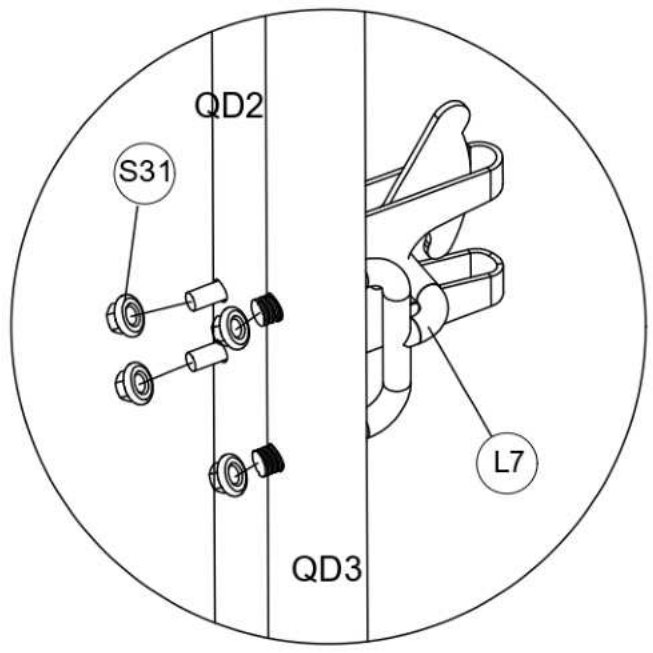
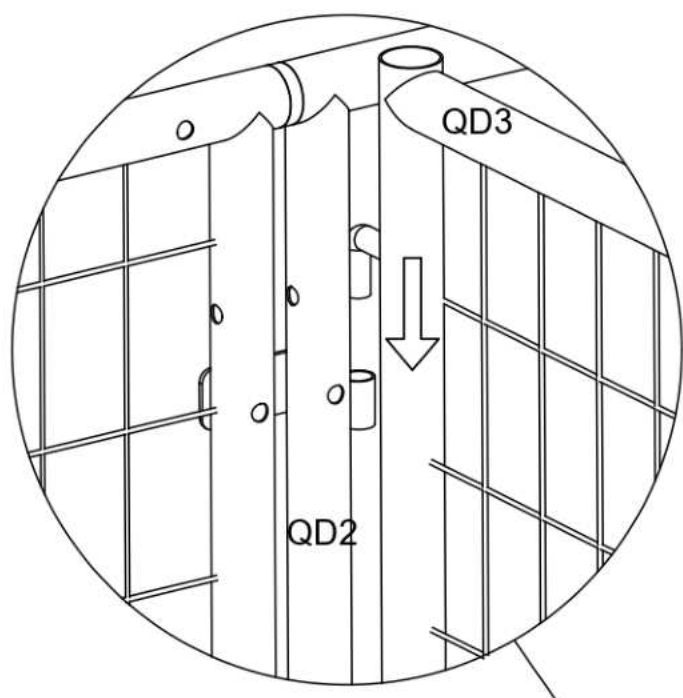

11.

BP1

S26



x6

x48

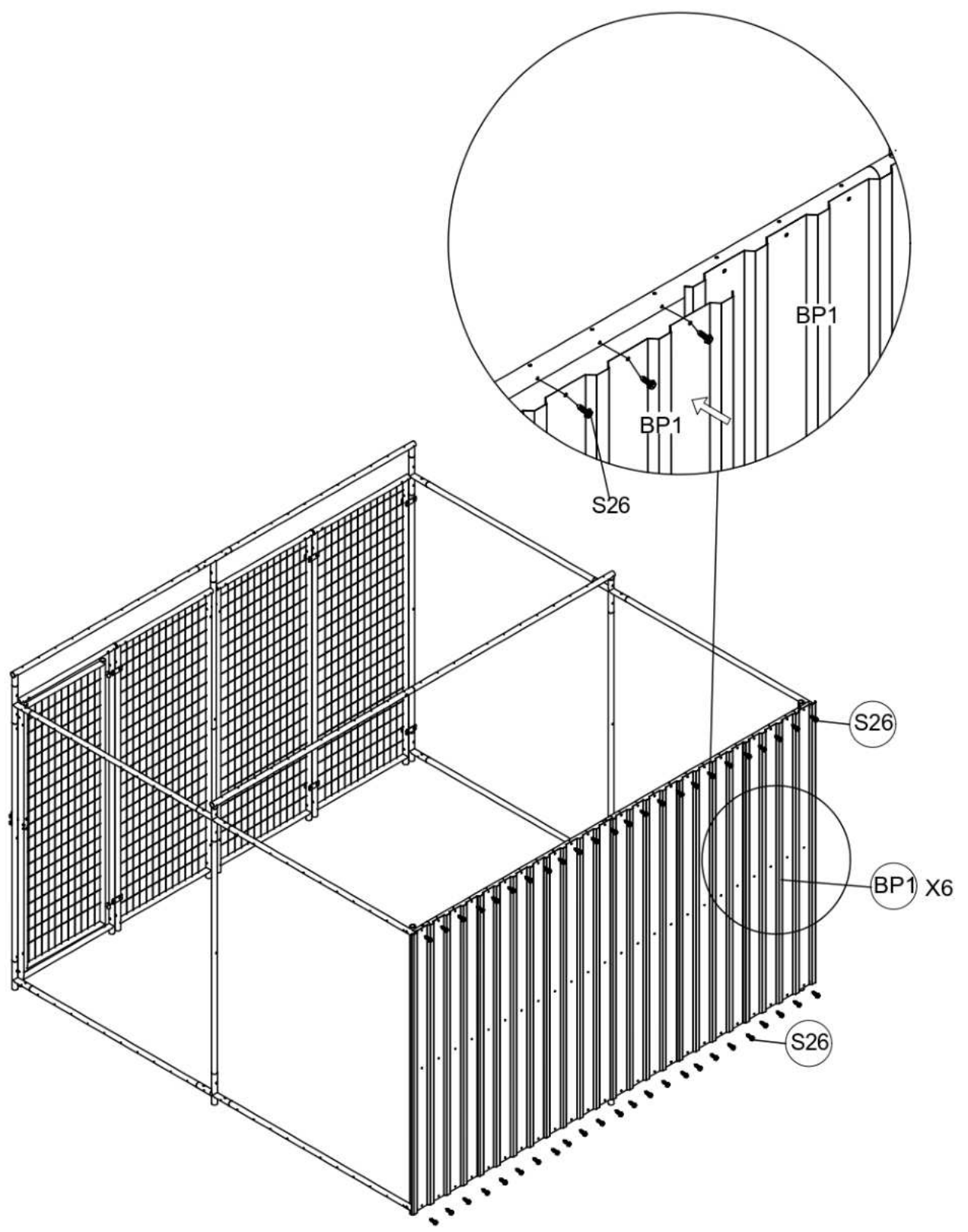

12.

ZU3

ZU4

G2

S26



x1



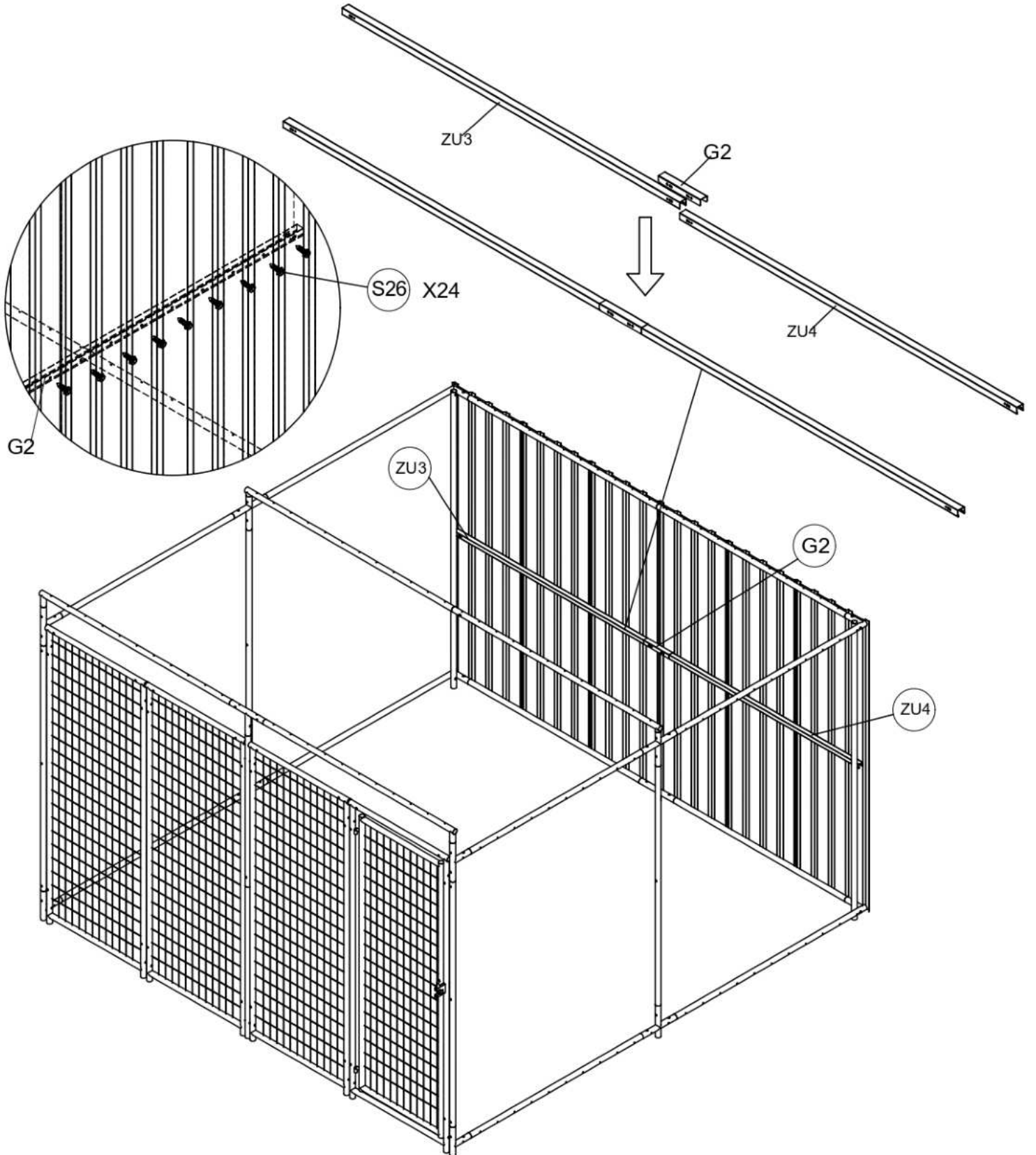

x1

x1

x24



13.

ZU1	ZU2	ZU5	G1	S28
				
x2	x1	x1	x2	x4

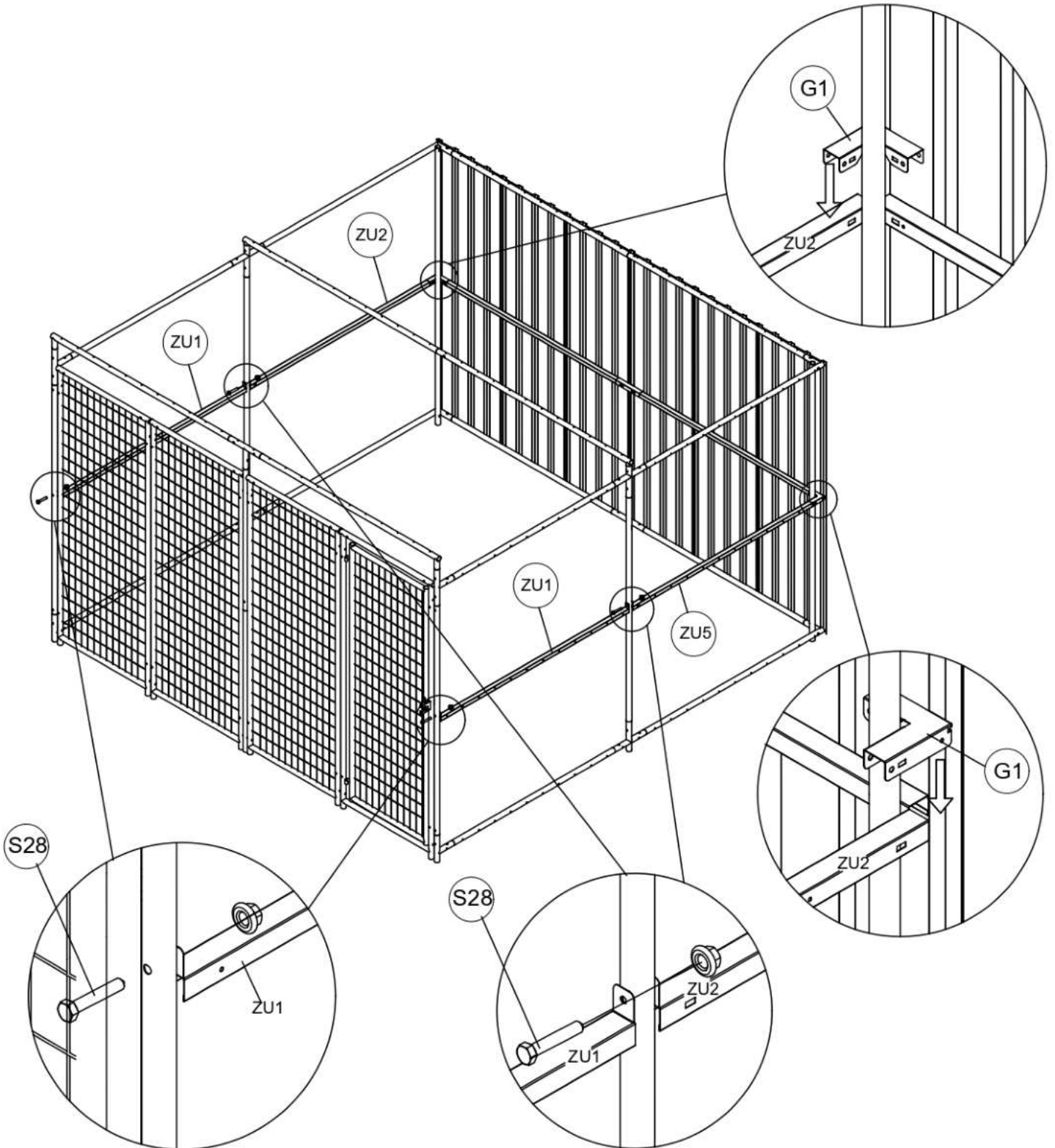

14.

BP1

S26



x12

x144

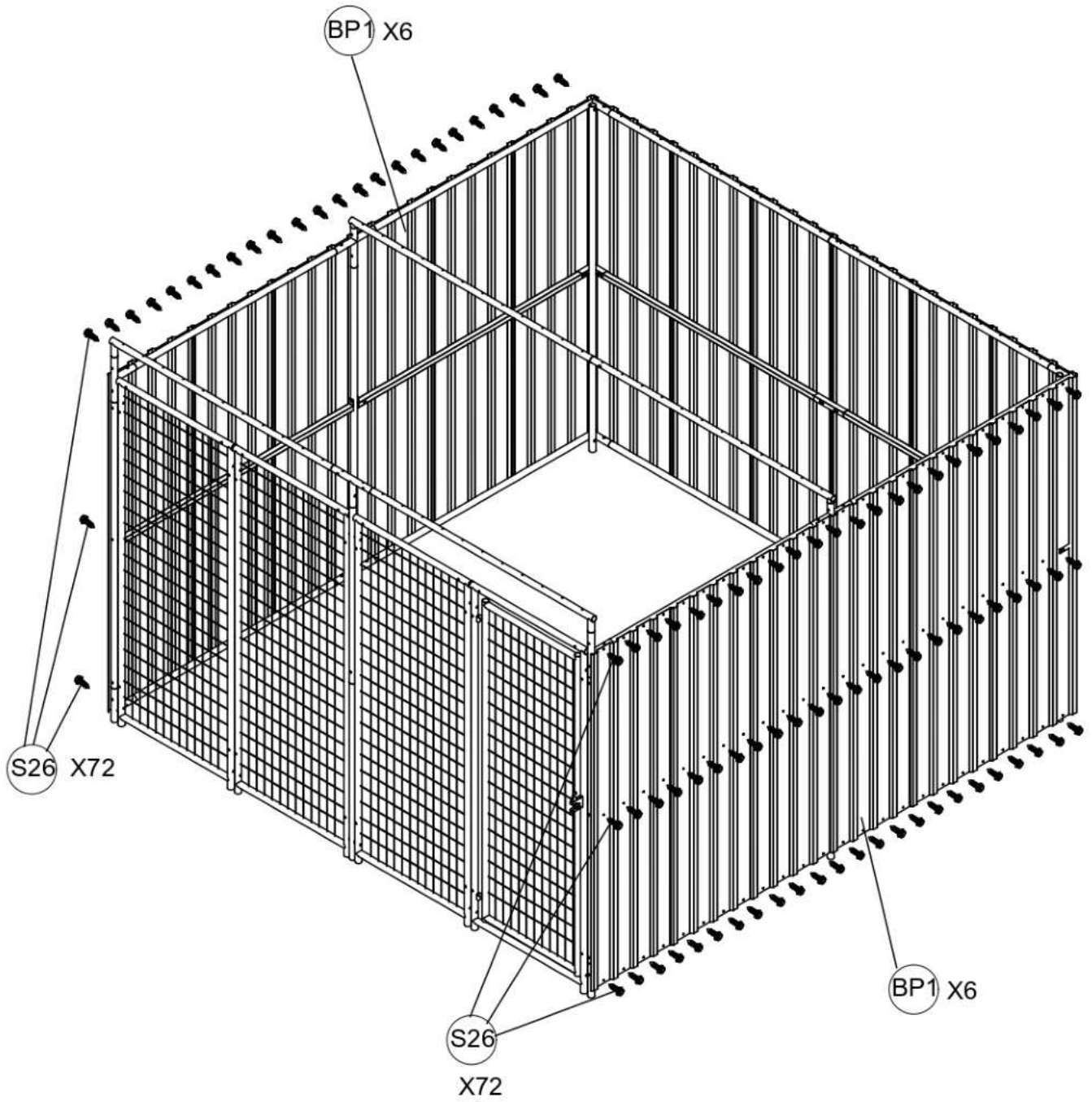

15.

BP11

S26



x6

x24

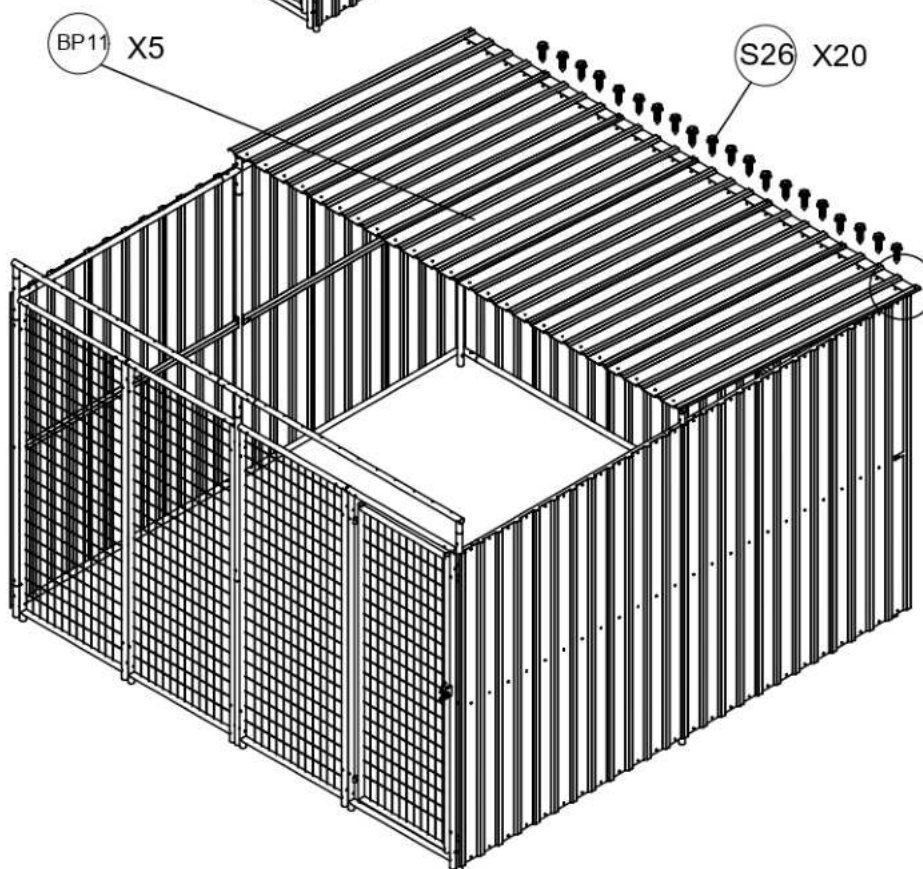
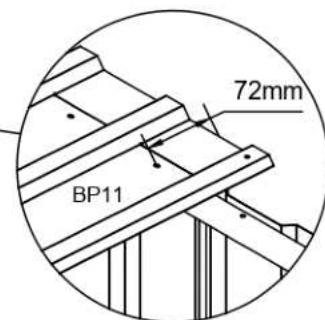
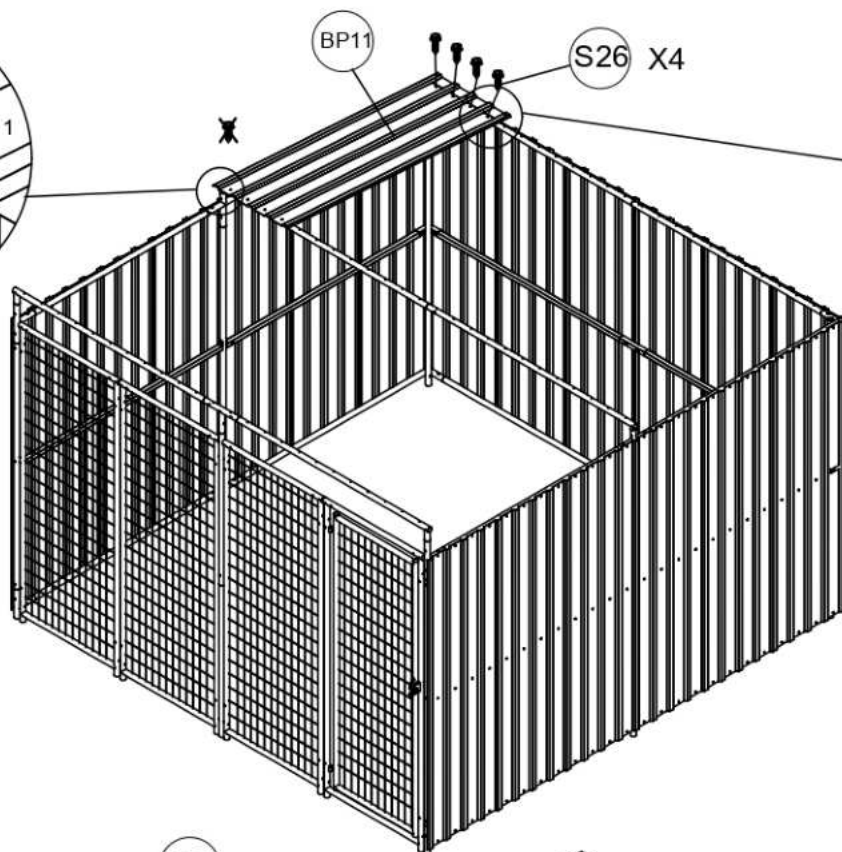
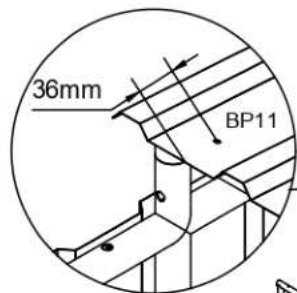

16.

BP12

S26



x6

x48

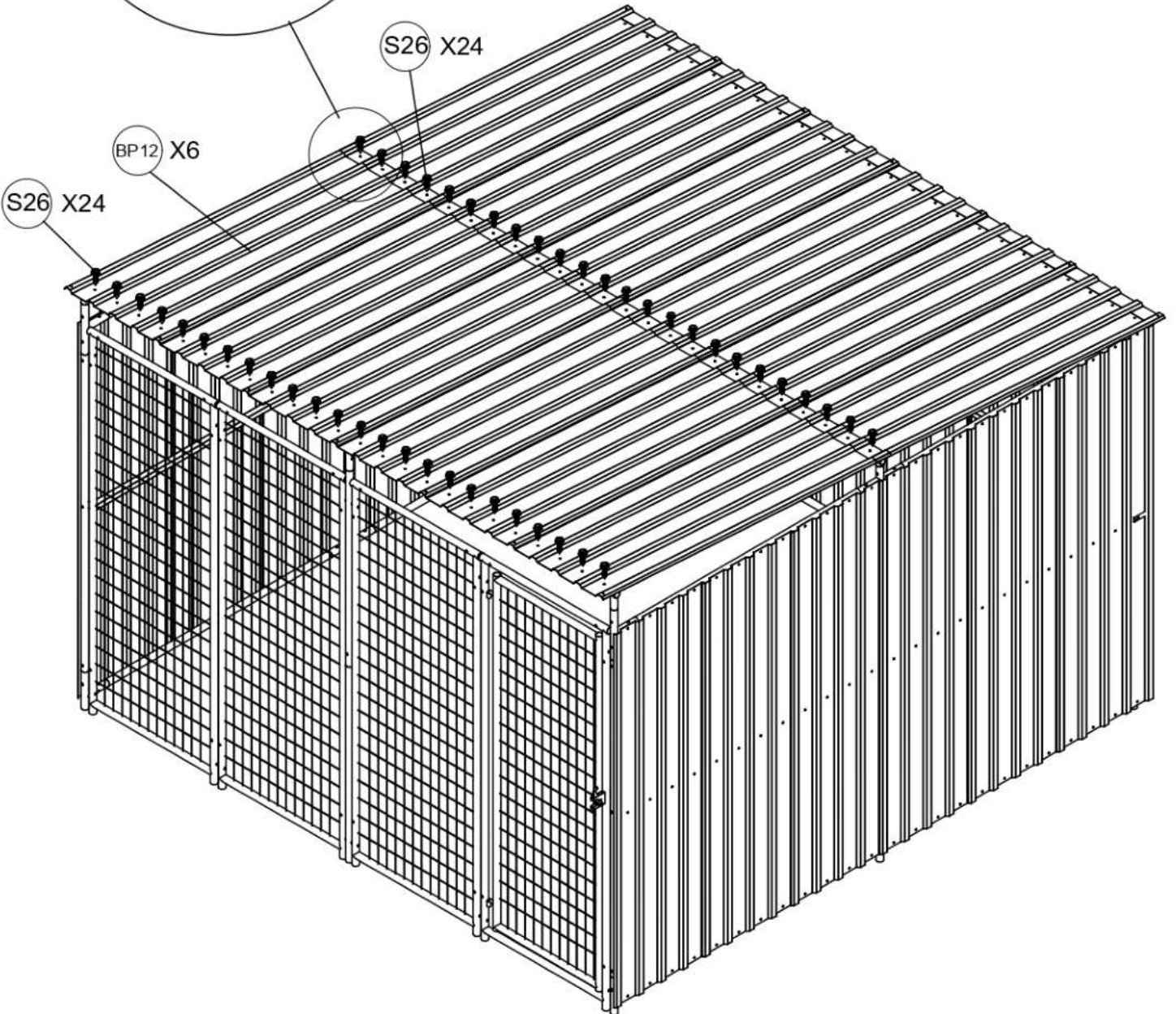
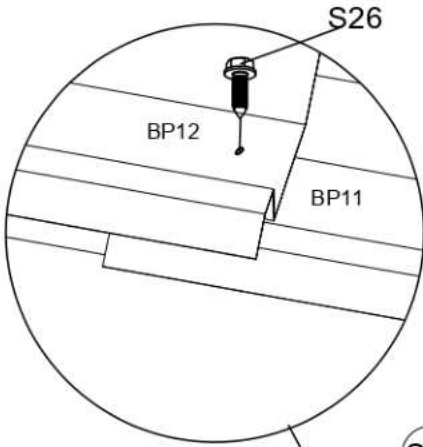

17.

ZA1
x4

ZA2
x4

M7
x4

S26
x16

